

Flansche DIN 2566

Gewindeflansche mit Dichtleiste
Nenndruck PN 10 / PN 16

Maße in mm

Nennweite	d1	Flansch					Ansatz	Dichtleiste		Schrauben		
		Whitworth-Rohrgewinde DIN 2999	D	b	k	h1	d3	d4	f	Anzahl	Gewinde	d2
6	10,2	R 1/8	75	12	50	18	20	32	2	4	M 10	11
8	13,5	R 1/4	80	12	55	18	25	38	2	4	M 10	11
10	17,2	R 3/8	90	14	60	20	30	40	2	4	M 12	14
15	21,3	R 1/2	95	14	65	20	35	45	2	4	M 12	14
20	26,9	R 3/4	105	16	75	24	45	58	2	4	M 12	14
25	33,7	R 1	115	16	85	24	52	68	2	4	M 12	14
32	42,4	R 1 1/4	140	16	100	26	60	78	2	4	M 16	18
40	48,3	R1 1/2	150	16	110	26	70	88	3	4	M 16	18
50	60,3	R 2	165	18	125	28	85	102	3	4	M 16	18
65	76,1	R 2 1/2	185	18	145	32	105	122	3	4	M 16	18
80	88,9	R 3	200	20	160	34	118	138	3	8	M 16	18
100	114,3	R 4	220	20	180	38	140	158	3	8	M 16	18
125	139,7	R 5	250	22	210	40	168	188	3	8	M 16	18
150	165,1	R 6	285	22	240	44	195	212	3	8	M20	22

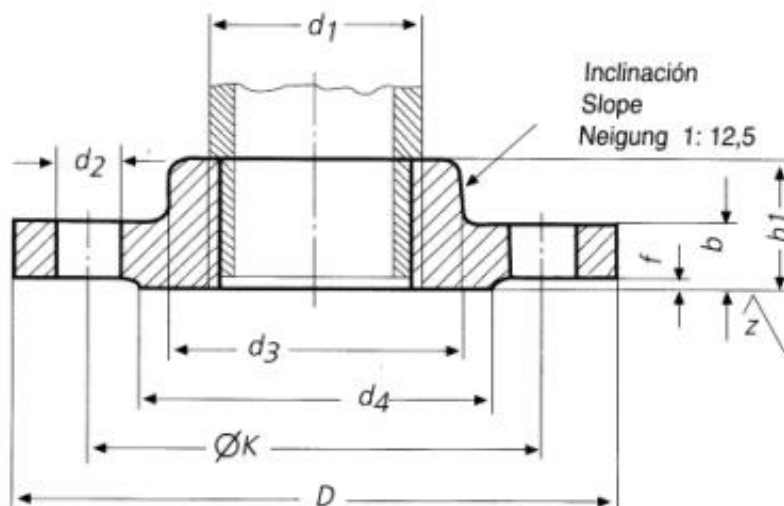

torneado
turning
dedreht

$$z/\sqrt{R_z} = 160$$